

## Home - Neutron Classes

Chapter No.	Chapter Name	Notes	Q/A	MCQ's
1.	Physical World	<a href="#">Click here</a>	<a href="#">Click here</a>	<a href="#">Click here</a>
2.	Units and Measurement	<a href="#">Click here</a>	<a href="#">Click here</a>	<a href="#">Click here</a>
3.	Motion in Straight line	<a href="#">Click here</a>	<a href="#">Click here</a>	<a href="#">Click here</a>
4.	Motion in a plane	<a href="#">Click here</a>	<a href="#">Click here</a>	<a href="#">Click here</a>
5.	Laws of Motion	<a href="#">Click here</a>	<a href="#">Click here</a>	<a href="#">Click here</a>
6.	Work, Energy and Power	<a href="#">Click here</a>	<a href="#">Click here</a>	<a href="#">Click here</a>
7.	System of Particles and Rotational Motion	<a href="#">Click here</a>	<a href="#">Click here</a>	<a href="#">Click here</a>
8.	Gravitation	<a href="#">Click here</a>	<a href="#">Click here</a>	<a href="#">Click here</a>
9.	Mechanical Properties of Solids	<a href="#">Click here</a>	<a href="#">Click here</a>	<a href="#">Click here</a>
10.	Mechanical Properties of Fluids	<a href="#">Click here</a>	<a href="#">Click here</a>	<a href="#">Click here</a>
11.	Thermal Properties of Matter	<a href="#">Click here</a>	<a href="#">Click here</a>	<a href="#">Click here</a>
12.	Thermodynamics	<a href="#">Click here</a>	<a href="#">Click here</a>	<a href="#">Click here</a>
13.	Kinetic theory	<a href="#">Click here</a>	<a href="#">Click here</a>	<a href="#">Click here</a>
14.	Oscillation	<a href="#">Click here</a>	<a href="#">Click here</a>	<a href="#">Click here</a>
15.	Waves	<a href="#">Click here</a>	<a href="#">Click here</a>	<a href="#">Click here</a>

## For More Study Material

<b>For Class 9 Science</b>	<a href="#">Click here</a>
<b>For Class 9 Mathematics</b>	<a href="#">Click here</a>
<b>For Class 10 Science</b>	<a href="#">Click here</a>
<b>For Class 10 Mathematics</b>	<a href="#">Click here</a>
<b>For Class 11 Physics</b>	<a href="#">Click here</a>
<b>For Class 11 Chemistry</b>	<a href="#">Click here</a>
<b>For Class 11 Biology</b>	<a href="#">Click here</a>
<b>For Class 11 mathematics</b>	<a href="#">Click here</a>
<b>For Class 12 Physics</b>	<a href="#">Click here</a>
<b>For Class 12 Chemistry</b>	<a href="#">Click here</a>
<b>For Class 12 Biology</b>	<a href="#">Click here</a>
<b>For Class 12 Mathematics</b>	<a href="#">Click here</a>

# LAWS OF MOTION

## 1. FORCE

- (a) A force is something which changes the state of rest or motion of a body. It causes a body to start moving if it is at rest or stop it, if it is in motion or deflect it from its initial path of motion.
- (b) Force is also defined as an interaction between two bodies. Two bodies can also exert force on each other even without being in physical contact, e.g., electric force between two charges, gravitational force between any two bodies of the universe.
- (c) Force is a vector quantity having SI unit Newton (N) and dimension  $[MLT^{-2}]$ .
- (d) **Superposition of force** : When many forces are acting on a single body, the resultant force is obtained by using the laws of vector addition.

$$\vec{F} = \vec{F}_1 + \vec{F}_2 + \dots + \vec{F}_n$$

The resultant of the two forces  $\vec{F}_1$  and  $\vec{F}_2$  acting at angle  $\theta$  is given by :

$$F = \sqrt{F_1^2 + F_2^2 + 2F_1F_2 \cos \theta}$$

The resultant force is directed at an angle  $\alpha$  with respect

$$\text{to force } F_1 \text{ where } \tan \alpha = \frac{F_2 \sin \theta}{F_1 + F_2 \cos \theta}$$

- (e) **Lami's theorem** : If three forces  $F_1$ ,  $F_2$  and  $F_3$  are acting simultaneously on a body and the body is in equilibrium, then according to Lami's theorem,

$$\frac{F_1}{\sin(\pi - \alpha)} = \frac{F_2}{\sin(\pi - \beta)} = \frac{F_3}{\sin(\pi - \gamma)}$$

where  $\alpha$ ,  $\beta$  and  $\gamma$  are the angles opposite to the forces  $F_1$ ,  $F_2$  &  $F_3$  respectively.

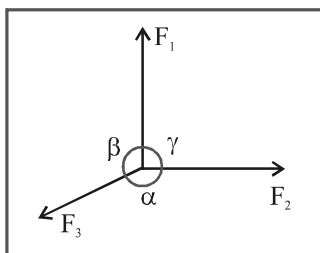

## 2. BASIC FORCES

There are, basically, four forces, which are commonly encountered in mechanics.

- (a) **Weight** : Weight of an object is the force with which earth attracts it. It is also called the force of gravity or the gravitational force.
- (b) **Contact Force** : When two bodies come in contact they exert forces on each other that are called contact forces.
  - (i) **Normal Force (N)** : It is the component of contact force normal to the surface. It measures how strongly the surfaces in contact are pressed together.
  - (ii) **Frictional Force (f)** : It is the component of contact force parallel to the surface. It opposes the relative motion (or attempted motion) of the two surfaces in contact.

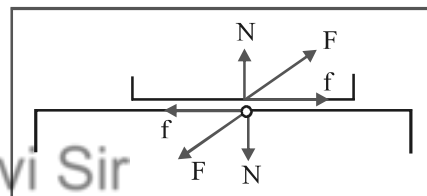

- (c) **Tension** : The force exerted by the end of a taut string, rope or chain is called the tension. The direction of tension is so as to pull the body while that of normal reaction is to push the body.
- (d) **Spring Force** : Every spring resists any attempt to change its length; the more you alter its length the harder it resists. The force exerted by a spring is given by  $F = -kx$ , where  $x$  is the change in length and  $k$  is the stiffness constant or spring constant (unit  $Nm^{-1}$ ).

## 3. NEWTON'S LAWS OF MOTION

### 3.1 First law of motion

- (a) Every body continues in its state of rest or of uniform motion in a straight line unless it is compelled by a resultant force to change that state.
- (b) This law is also known as **law of inertia**. Inertia is the property of inability of a body to change its position of rest or uniform motion in a straight line unless some external force acts on it.
- (c) Mass is a measure of inertia of a body.

- (d) A frame of reference in which Newton's first law is valid is called **inertial frame**, i.e., if a frame of reference is at rest or in uniform motion it is called **inertial**, otherwise **non-inertial**.

### 3.2 Second law of motion

- (a) This law gives the magnitude of force.  
 (b) According to second law of motion, rate of change of momentum of a body is proportional to the resultant force

acting on the body, i.e.,  $\vec{F} \propto \left( \frac{d\vec{p}}{dt} \right)$

Here, the change in momentum takes place in the direction of the applied resultant force. Momentum,  $\vec{p} = m \vec{v}$  is a measure of sum of the motion contained in the body.

- (c) **Unit force** : It is defined as the force which changes the momentum of a body by unity in unit time. According to

$$\text{this, } \vec{F} = \frac{d\vec{p}}{dt} = \frac{d}{dt} (m \vec{v}) = m \frac{d\vec{v}}{dt} + \vec{v} \frac{dm}{dt}.$$

If the mass of the system is finite and remains constant w.r.t. time, then  $(dm/dt) = 0$  and

$$\vec{F} = m \left( \frac{d\vec{v}}{dt} \right) = m \vec{a} = \left( \frac{\vec{p}_2 - \vec{p}_1}{t} \right)$$

- (d) External force acting on a body may accelerate it either by changing the magnitude of velocity or direction of velocity or both.

(i) **If the force is parallel or antiparallel to the motion**, it changes only the magnitude of  $\vec{v}$  but not the direction. So, the path followed by the body is a **straight line**.

(ii) **If the force is acting  $\perp$  to the motion of body**, it changes only the direction but not the magnitude of  $\vec{v}$ . So, the path followed by the body is a **circle** (uniform circular motion).

(iii) **If the force acts at an angle to the motion of a body**, it changes both the magnitude and direction of  $\vec{v}$ . In this case path followed by the body may be **elliptical, non-uniform circular, parabolic or hyperbolic**.

- (e) To apply Newton's Second Law in non-inertial frame refer **Section 17 (Page no. 10)**

### 3.3 Third law of motion

- (a) According to this law, for every action there is an equal and opposite reaction. When two bodies A and B exert force on each other, the force by A on B (i.e., action represented by  $F_{AB}$ ), is always equal and opposite to the

force by B on A (i.e., reaction represented  $F_{BA}$ ). Thus,  $F_{AB} = -F_{BA}$ .

- (b) The two forces involved in any interaction between two bodies are called **action and reaction**. But we cannot say that a particular force is action and the other one is reaction.  
 (c) **Action and Reaction always act on different bodies.**

## 4. LINEAR MOMENTUM

The linear momentum of a body is defined as the product of the mass of the body and its velocity i.e.

Linear momentum = mass  $\times$  velocity

If a body of mass  $m$  is moving with a velocity  $\vec{v}$ , its linear momentum  $\vec{p}$  is given by

$$\vec{p} = m \vec{v}$$

Linear momentum is a vector quantity. Its direction is the same as the direction of velocity of the body.

the SI unit of linear momentum is  $\text{kg ms}^{-1}$  and the cgs unit of linear momentum is  $\text{g cm s}^{-1}$ .

### 4.1 Impulse

Impulse of a force, which is the product of average force during impact and the time for which the impact lasts, is measured by the total change in linear momentum produced during the impact.

impulse of a force is a measure of total effect of the force.

The force which act on bodies for short time are called impulsive forces. For example :

- (i) In hitting a ball with a bat,  
 (ii) In driving a nail into a wooden block with a hammer,  
 (iii) In firing a gun, etc.

An impulsive force does not remain constant, but changes first from zero to maximum and then from maximum to zero. Thus it is not possible to measure easily the value of impulsive force because it changes with time. In such cases, we measure the total effect of the force, called impulse. Hence

$$\vec{I} = \vec{F}_{av} \times t = \vec{p}_2 - \vec{p}_1$$

## 5. APPARENT WEIGHT OF A BODY IN A LIFT

- (a) **When the lift is at rest or moving with uniform velocity, i.e.,  $a=0$  :**

## LAWS OF MOTION

$$mg - R = 0 \quad \text{or} \quad R = mg \quad \therefore W_{\text{app}} = W_0$$

(b) **When the lift moves upwards with an acceleration  $a$  :**

$$R - mg = ma \quad \text{or} \quad R = m(g + a) = mg \left(1 + \frac{a}{g}\right)$$

$$\therefore W_{\text{app}} = W_0 \left(1 + \frac{a}{g}\right)$$

(c) **When the lift moves downwards with an acceleration  $a$  :**

$$mg - R = ma \quad \text{or} \quad R = m(g - a) = mg \left(1 - \frac{a}{g}\right)$$

$$\therefore W_{\text{app}} = W_0 \left(1 - \frac{a}{g}\right)$$

Here, if  $a > g$ ,  $W_{\text{app}}$  will be negative. Negative apparent weight will mean that the body is pressed against the roof of the lift instead of floor.

(d) **When the lift falls freely, i.e.,  $a = g$  :**

$$R = m(g - g) = 0 \quad \therefore W_{\text{app}} = 0$$

( $W_{\text{app}} = R =$  reaction of supporting surface and  $W_0 = mg =$  true weight.)

## 6. PRINCIPLE OF OF CONSERVATION OF LINEAR MOMENTUM

**According to this principle, in an isolated system, the vector sum of the linear momenta of all the bodies of the system is conserved and is not affected due to their mutual action and reaction.**

Thus, in an isolated system (i.e., a system with no external force), mutual forces between pairs of particles in the system can cause changes in linear momentum of individual particles. But as the mutual forces for each pair are equal and opposite, the linear momentum changes cancel in pairs, and the total linear momentum remains unchanged. Hence the total linear momentum of an isolated system of interacting particles is conserved. This principle is an important consequence of second and third laws of motion.

Let us consider an isolated system comprising of two bodies A and B, with initial linear momenta  $\vec{p}_A$  and  $\vec{p}_B$ . Let them collide for a small time  $\Delta t$  and separate with final linear momenta  $\vec{p}'_A$  and  $\vec{p}'_B$  respectively. During collision,

If  $\vec{F}_{AB}$  is force on A exerted by B, and  $\vec{F}_{BA}$  is force on B exerted by A,

then, according to Newton's second law,

$$\vec{F}_{AB} \times \Delta t = \text{change in linear momentum of A} = \vec{p}'_A - \vec{p}_A$$

$$\vec{F}_{BA} \times \Delta t = \text{change in linear momentum of B} = \vec{p}'_B - \vec{p}_B$$

According to Newton's third law,  $\vec{F}_{AB} = -\vec{F}_{BA}$

$$\therefore \text{From eqns. } \vec{p}'_A - \vec{p}_A = -(\vec{p}'_B - \vec{p}_B) \quad \text{or} \quad \vec{p}'_A + \vec{p}'_B = \vec{p}_A + \vec{p}_B$$

which shows that total final linear momentum of the isolated system is equal to its total initial linear momentum. This proves the principle of conservation of linear momentum.

## 7. FRICTION

**Friction as an opposing force that comes into play when one body actually moves (slides or rolls) or even tries to move over the surface of another body.**

Thus force of friction is the force that develops at the surfaces of contact of two bodies and impedes (opposes) their relative motion.

(i) Frictional force is independent of the area of contact. This is because with increase in area of contact, force of adhesion also increases (in the same ratio). And the adhesive pressure responsible for friction, remains the same.

(ii) When the surfaces in contact are extra smooth, distance between the molecules of the surfaces in contact decreases, increasing the adhesive force between them. Therefore, the adhesive pressure increases, and so does the force of friction.

### 7.1 Static Friction, Limiting Friction and Kinetic Friction

*The opposing force that comes into play when one body tends to move over the surface of another, but the actual motion has yet not started is called Static friction.*

*Limiting friction is the maximum opposing force that comes into play, when one body is just at the verge of moving over the surface of the other body.*

*Kinetic friction or dynamic friction is the opposing force that comes into play when one body is actually moving over the surface of another body.*

Kinetic friction is always slightly less than the limiting friction.

**7.2 Laws of limiting friction**

**(a) Static Friction**

(i) The force of friction always acts in a direction opposite to the direction of relative motion, i.e., friction is of perverse nature.

(ii) The maximum force of static friction,  $f_{ms}$  (called limiting friction) is directly proportional to the normal reaction (R) between the two surfaces in contact. i.e.,

$$f_{ms} \propto R \quad \dots(1)$$

(iii) The force of limiting friction depends upon the nature and the state of polish of the two surfaces in contact and it acts tangential to the interface between the two surfaces.

(iv) The force of limiting friction is independent of the extent of the area of the surfaces in contact so long as the normal reaction remains the same.

**7.3 Coefficient of Static Friction**

We know that,  $f_{ms} \propto R$  or  $f_{ms} = \mu_s R$

or 
$$\mu_s = \frac{f_{ms}}{R} \quad \dots(2)$$

Here,  $\mu_s$  is a constant of proportionality and is called the coefficient of static friction. Thus

Coefficient of static friction for any pair of surfaces in contact is equal to the ratio of the limiting friction and the normal reaction.

$\mu_s$ , being a pure ratio, has got no units and its value depends upon the nature of the surfaces in contact. Further,  $\mu_s$  is usually less than unity and is never equal to zero.

Since the force of static friction ( $f_s$ ) can have any value from zero to maximum ( $f_{ms}$ ), i.e.  $f_s \leq f_{ms}$ , eqn. (2) is generalised to

$$f_s \leq \mu_s R \quad \dots(3)$$

**Kinetic Friction**

The laws of kinetic friction are exactly the same as those for static friction. Accordingly, the force of kinetic friction is also directly proportional to the normal reaction, i.e.,

$$f_k \propto R \quad \text{or} \quad f_k = \mu_k R \quad \dots(4)$$

**8. ROLLING FRICTION**

The opposing force that comes into play when a body rolls over the surface of another body is called the rolling friction.

**Cause of rolling friction.** Let us consider a wheel which is rolling along a road. As the wheel rolls along the road, it slightly presses into the surface of the road and is itself slightly compressed as shown in Fig.

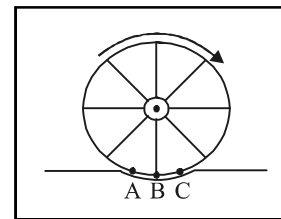

Thus, a rolling wheel :

- (i) constantly climbs a 'hill' (BC) in front of it, and
- (ii) has to simultaneously get itself detached from the road (AB) behind it. The force of adhesion between the wheel and the road opposes this process.

Both these processes are responsible for rolling friction.

**9. ANGLE OF FRICTION**

The angle of friction between any two surfaces in contact is defined as the angle which the resultant of the force of limiting friction F and normal reaction R makes with the direction of normal reaction R.

It is represented by  $\theta$ .

In fig. OA represents the normal reaction R which balances the weight mg of the body. OB represent F, the limiting force of sliding friction, when the body tends to move to the right. Complete the parallelogram OACB. Join OC. This represents the resultant of R and F. By definition,  $\angle AOC = \theta$  is the angle of friction between the two bodies in contact.

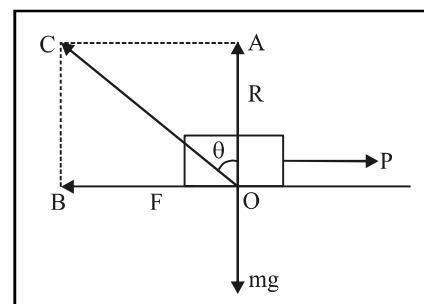

The value of angle of friction depends on the nature of materials of the surfaces in contact and the nature of the surfaces.

**Relation between  $\mu$  and  $\theta$**

In  $\Delta AOC$ , 
$$\tan \theta = \frac{AC}{OA} = \frac{OB}{OA} = \frac{F}{R} = \mu \quad \dots(5)$$

Hence  $\mu = \tan \theta$  ... (6)

i.e. coefficient of limiting friction between any two surfaces in contact is equal to tangent of the angle of friction between them.

**10. ANGLE OF REPOSE OR ANGLE OF SLIDING**

**Angle of repose or angle of sliding is defined as the minimum angle of inclination of a plane with the horizontal, such that a body placed on the plane just begins to slide down.**

It is represented by  $\alpha$ . Its value depends on material and nature of the surfaces in contact.

In fig., AB is an inclined plane such that a body placed on it just begins to slide down.  $\angle BAC = \alpha =$  angle of repose.

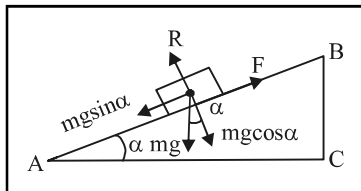

The various forces involved are :

- (i) weight,  $mg$  of the body, acting vertically downwards,
- (ii) normal reaction,  $R$ , acting perpendicular to  $AB$ ,
- (iii) Force of friction  $F$ , acting up the plane  $AB$ .

Now,  $mg$  can be resolved into two rectangular components :  $mg \cos \alpha$  opposite to  $R$  and  $mg \sin \alpha$  opposite to  $F$ . In equilibrium,

$$F = mg \sin \alpha \quad \dots (7)$$

$$R = mg \cos \alpha \quad \dots (8)$$

Dividing (7) by (8), we get

$$\frac{F}{R} = \frac{mg \sin \alpha}{mg \cos \alpha}, \text{ i.e., } \mu = \tan \alpha$$

Hence coefficient of limiting friction between any two surfaces in contact is equal to the tangent of the angle of repose between them.



Combining (6) and (9), we obtain

$$\mu = \tan \theta = \tan \alpha$$

$$\therefore \theta = \alpha$$

i.e. angle of friction is equal to angle of repose.

**11. METHODS OF CHANGING FRICTION**

Some of the ways of reducing friction are :

- (i) By polishing.
- (ii) By lubrication.
- (iii) By proper selection of materials.
- (iv) By Streamlining.
- (v) By using ball bearings.

**12. DYNAMICS OF UNIFORM CIRCULAR MOTION  
CONCEPT OF CENTRIPETAL FORCE**

**Centripetal force is the force required to move a body uniformly in a circle. This force acts along the radius and towards the centre of the circle.**

In fact, when a body moves in a circle, its direction of motion at any instant is along the tangent to the circle at that instant. From fig., we find that the direction of motion of the body moving in a circle goes on changing continuously.

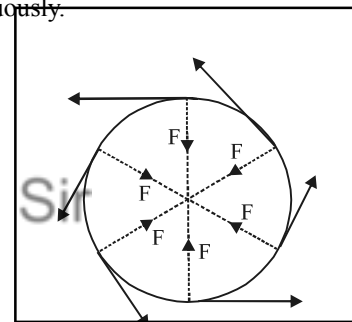

According to Newton's first law of motion, a body cannot change its direction of motion by itself. An external force is required for this purpose. It is this external force which is called the centripetal force.

On account of a continuous change in the direction of motion of the body, there is a change in velocity of the body, and hence it undergoes an acceleration, called centripetal acceleration or radial acceleration.

An expression for centripetal force is

$$\text{i.e. } F = m v^2 / r = m r \omega^2$$

**13. CENTRIFUGAL FORCE**

The natural tendency of a body is to move uniformly along a straight line. When we apply centripetal force on the body, it is forced to move along a circle. While moving actually along a circle, the body has a constant tendency to regain its natural straight line path. This tendency gives

rise to a force called centrifugal force. Hence

**Centrifugal force is a force that arises when a body is moving actually along a circular path, by virtue of tendency of the body to regain its natural straight line path.**

Centrifugal forces can be regarded as the reaction of centripetal force. As forces of action and reaction are always equal and opposite, therefore, magnitude of centrifugal force =  $m v^2/r$ , which is same as that of centripetal force. However, direction of centrifugal force is opposite to the direction of centripetal force i.e. **centrifugal force acts along the radius and away from the centre of the circle.**

Note that centripetal and centrifugal forces, being the forces of action and reaction act always on different bodies. For example, when a piece of stone tied to one end of a string is rotated in a circle, centripetal force  $F_1$  is applied on the stone by the hand. In turn, the hand is pulled outwards by centrifugal force  $F_2$  acting on it, due to tendency of the stone to regain its natural straight line path. The centripetal and centrifugal forces are shown in Fig.

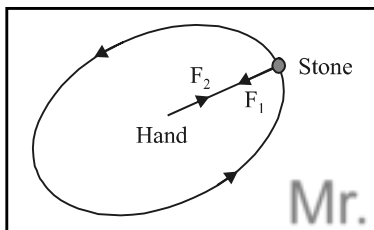

#### 14. ROUNDING A LEVEL CURVED ROAD

When a vehicle goes round a curved road, it requires some centripetal force. While rounding the curve, the wheels of the vehicle have a tendency to leave the curved path and regain the straight line path. Force of friction between the wheels and the road opposes this tendency of the wheels. This force (of friction) therefore, acts, towards the centre of the circular track and provides the necessary centripetal force.

Three forces are acting on the car, fig.

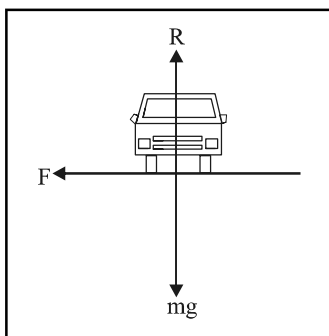

- (i) The weight of the car,  $mg$ , acting vertically downwards,
- (ii) Normal reaction  $R$  of the road on the car, acting vertically upwards,
- (iii) Frictional Force  $F$ , along the surface of the road, towards the centre of the turn, as explained already.

As there is no acceleration in the vertical direction,

$$R - mg = 0 \text{ or } R = mg \quad \dots(1)$$

The centripetal force required for circular motion is along the surface of the road, towards the centre of the turn. As explained above, it is the static friction that provides the necessary centripetal force. Clearly,

$$\frac{mv^2}{r} \leq F \quad \dots(2)$$

where  $v$  is velocity of car while turning and  $r$  is radius of circular track.

As  $F = \mu_s R = \mu_s mg$ , [using (1)]

where  $\mu_s$  is coefficient of static friction between the tyres and the road. Therefore, from (2),

$$\frac{mv^2}{r} \leq \mu_s mg \text{ or } v \leq \sqrt{\mu_s rg} \therefore v_{\max} = \sqrt{\mu_s rg} \quad \dots(3)$$

Hence the maximum velocity with which a vehicle can go round a level curve ; without skidding is

$$v = \sqrt{\mu_s rg}$$

The value of  $v$  depends on radius  $r$  of the curve and on coefficient of static friction ( $\mu_s$ ) between the tyres and the road. Clearly,  $v$  is independent of mass of the car.

#### 15. BANKING OF ROADS

The maximum permissible velocity with which a vehicle can go round a level curved road without skidding depends on  $\mu$ , the coefficient of friction between the tyres and the road. The value of  $\mu$  decreases when road is smooth or tyres of the vehicle are worn out or the road is wet and so on. Thus force of friction is not a reliable source for providing the required centripetal force to the vehicle.

A safer course of action would be to raise outer edge of the curved road above the inner edge. By doing so, a component of normal reaction of the road shall be spared to provide the centripetal force. **The phenomenon of raising outer edge of the curved road above the inner edge is called banking of roads.** We can calculate the angle of banking  $\theta$ , as detailed below:

In Fig.,  $OX$  is a horizontal line.  $OA$  is the level of banked



curved road whose outer edge has been raised.  $\angle XOA = \theta =$  angle of banking.

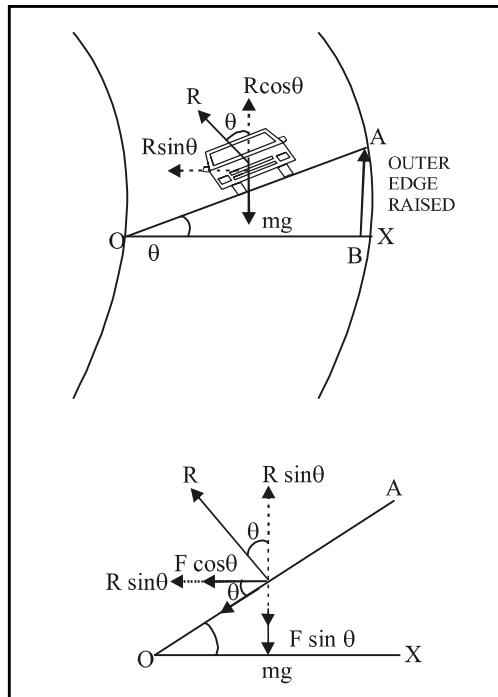

Three forces are acting on the vehicle as shown in Fig.

- (i) Weight  $mg$  of the vehicle acting vertically downwards.
- (ii) Normal reaction  $R$  of the banked road acting upwards in a direction perpendicular to OA.
- (iii) Force of friction  $F$  between the banked road and the tyres, acting along AO.

$R$  can be resolved into two rectangular components :-

- (i)  $R \cos \theta$ , along vertically upward direction
- (ii)  $R \sin \theta$ , along the horizontal, towards the centre of the curved road.

$F$  can also be resolved into two rectangular components :

- (i)  $F \cos \theta$ , along the horizontal, towards the centre of curved road
- (ii)  $F \sin \theta$ , along vertically downward direction.

As there is no acceleration along the vertical direction, the net force along this direction must be zero. Therefore,

$$R \cos \theta = mg + F \sin \theta \quad \dots(1)$$

If  $v$  is velocity of the vehicle over the banked circular road of radius  $r$ , then centripetal force required  $= mv^2/r$ . This is provided by the horizontal components of  $R$  and  $F$  as shown in Fig.

$$\therefore R \sin \theta + F \cos \theta = \frac{mv^2}{r} \quad \dots(2)$$

But  $F \leq \mu_s R$ , where  $\mu_s$  is coefficient of static friction between the banked road and the tyres. To obtain  $v_{\max}$ , we put  $F = \mu_s R$  in (1) and (2).

$$R \cos \theta = mg + \mu_s R \sin \theta \quad \dots(3)$$

$$\text{and } R \sin \theta + \mu_s R \cos \theta = \frac{mv^2}{r} \quad \dots(4)$$

From (3),  $R (\cos \theta - \mu_s \sin \theta) = mg$

$$R = \frac{mg}{\cos \theta - \mu_s \sin \theta} \quad \dots(5)$$

$$\text{From (4), } R (\sin \theta + \mu_s \cos \theta) = \frac{mv^2}{r}$$

$$\text{Using (5), } \frac{mg (\sin \theta + \mu_s \cos \theta)}{(\cos \theta - \mu_s \sin \theta)} = \frac{mv^2}{r}$$

$$\therefore v^2 = \frac{rg (\sin \theta + \mu_s \cos \theta)}{(\cos \theta - \mu_s \sin \theta)} =$$

$$\frac{rg \cos \theta (\tan \theta + \mu_s)}{\cos \theta (1 - \mu_s \tan \theta)}$$

$$v = \left[ \frac{rg (\mu_s + \tan \theta)}{(1 - \mu_s \tan \theta)} \right]^{1/2} \quad \dots(6)$$

This is the max. velocity of vehicle on a banked road.

**Discussion**

1. If  $\mu_s = 0$ , i.e., if banked road is perfectly smooth, then from eqn. (51),

$$v_0 = (rg \tan \theta)^{1/2} \quad \dots(7)$$

This is the speed at which a banked road can be rounded even when there is no friction. Driving at this speed on a banked road will cause almost no wear and tear of the tyres.

$$\text{From (7), } v_0^2 = rg \tan \theta \text{ or } \tan \theta = v_0^2 / rg \quad \dots(8)$$

2. If speed of vehicle is less than  $v_0$ , frictional force will be up the slope. Therefore, the vehicle can be parked only if  $\tan \theta \leq \mu_s$ .

Roads are usually banked for the average speed of vehicles passing over them. However, if the speed of a vehicle is

somewhat less or more than this, the self adjusting static friction will operate between the tyres and the road, and the vehicle will not skid.

The speed limit at which the curve can be negotiated safely is clearly indicated on the sign boards erected along the curved roads.

Note that curved railway tracks are also banked for the same reason. The level of outer rail is raised a little above the level of inner rail, while laying a curved railway track.

### 16. BENDING OF A CYCLIST

When a cyclist takes a turn, he also requires some centripetal force. If he keeps himself vertical while turning, his weight is balanced by the normal reaction of the ground. In that event, he has to depend upon force of friction between the tyres and the road for obtaining the necessary centripetal force. As force of friction is small and uncertain, dependence on it is not safe.

To avoid dependence on force of friction for obtaining centripetal force, the cyclist has to bend a little inwards from his vertical position, while turning. By doing so, a component of normal reaction in the horizontal direction provides the necessary centripetal force. To calculate the angle of bending with vertical, suppose

- m = mass of the cyclist,
- v = velocity of the cyclist while turning,
- r = radius of the circular path,
- $\theta$  = angle of bending with vertical.

In Fig., we have shown weight of the cyclist ( $mg$ ) acting vertically downwards at the centre of gravity C. R is force of reaction of the ground on the cyclist. It acts at an angle  $\theta$  with the vertical.

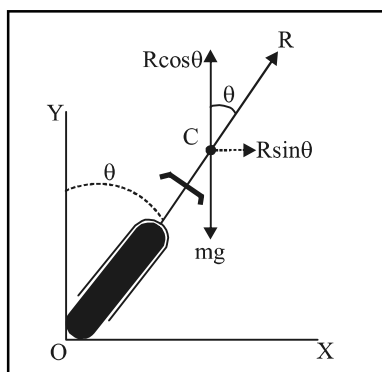

R can be resolved into two rectangular components:  
 $R \cos \theta$ , along the vertical upward direction,  
 $R \sin \theta$ , along the horizontal, towards the centre of the circular track.

In equilibrium,  $R \cos \theta$  balances the weight of the cyclist i.e.

$$R \cos \theta = mg \quad \dots(1)$$

and  $R \sin \theta$  provides the necessary centripetal force ( $m v^2/r$ )

$$\therefore R \sin \theta = \frac{m v^2}{r} \quad \dots(2)$$

Dividing (2) by (1), we get  $\frac{R \sin \theta}{R \cos \theta} = \frac{m v^2}{r mg}$

$$\tan \theta = \frac{v^2}{r g}$$

Clearly,  $\theta$  would depend on  $v$  and  $r$ .

For a safe turn,  $\theta$  should be small, for which  $v$  should be small and  $r$  should be large i.e. turning should be at a slow speed and along a track of larger radius. This means, a safe turn should neither be fast nor sharp.

### 17. PSEUDO FORCE

If observer O is non-inertial with acceleration  $\vec{a}_0$  and still wants to apply Newton's Second Law on particle P, then observer has to add a "Pseudo force" in addition to real forces on particle P.

$$\vec{F}_{\text{Pseudo}} = -m_p \vec{a}_0$$

Thus, Newton Second Law with respect to O will be

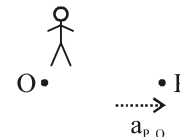

$$\vec{F}_{\text{Real}} + \vec{F}_{\text{Pseudo}} = m_p \vec{a}_{p,o}$$

$$\text{i.e., } \vec{F}_{\text{Real}} - m_p \vec{a}_0 = m_p \vec{a}_{p,o}$$

Where  $\vec{a}_{p,o}$  is acceleration of P with respect to observer O.



Note...

If observer is in rotating frame then Pseudo force is called "Centrifugal force".

**Remember :** Pseudo force is required only and only if observer is non-inertial.e.g.

- (i) Study of motion with respect to accelerating lift.
- (ii) Study of motion with respect to accelerating wedge.

**18. FORCE**

- (a) A force is something which changes the state of rest or motion of a body. It causes a body to start moving if it is at rest or stop it, if it is in motion or deflect it from its initial path of motion.
- (b) Force is also defined as an interaction between two bodies. Two bodies can also exert force on each other even without being in physical contact, e.g., electric force between two charges, gravitational force between any two bodies of the universe.
- (c) Force is a vector quantity having SI unit Newton (N) and dimension  $[MLT^{-2}]$ .
- (d) **Superposition of force :** When many forces are acting on a single body, the resultant force is obtained by using the laws of vector addition.  $\vec{F} = \vec{F}_1 + \vec{F}_2 + \dots + \vec{F}_n$

The resultant of the two forces  $\vec{F}_1$  and  $\vec{F}_2$  acting at angle  $\theta$  is given by :

$$F = \sqrt{F_1^2 + F_2^2 + 2F_1F_2 \cos \theta}$$

The resultant force is directed at an angle  $\alpha$  with respect

to force  $F_1$  where  $\tan \alpha = \frac{F_2 \sin \theta}{F_1 + F_2 \cos \theta}$

- (e) **Lami's theorem :** If three forces  $F_1$ ,  $F_2$  and  $F_3$  are acting simultaneously on a body and the body is in equilibrium, then according to Lami's theorem,

$$\frac{F_1}{\sin(\pi - \alpha)} = \frac{F_2}{\sin(\pi - \beta)} = \frac{F_3}{\sin(\pi - \gamma)}$$

where  $\alpha$ ,  $\beta$  and  $\gamma$  are the angles opposite to the forces  $F_1$ ,  $F_2$  and  $F_3$  respectively.

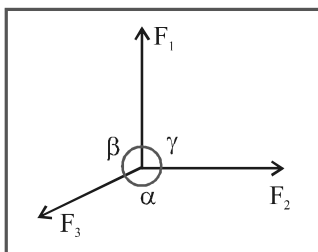

**19. BASIC FORCES**

There are, basically, five forces, which are commonly encountered in mechanics.

- (a) **Weight :** Weight of an object is the force with which earth attracts it. It is also called the force of gravity or the gravitational force.
- (b) **Contact Force :** When two bodies come in contact they exert forces on each other that are called contact forces.
  - (i) **Normal Force (N) :** It is the component of contact force normal to the surface. It measures how strongly the surfaces in contact are pressed together.
  - (ii) **Frictional Force (f) :** It is the component of contact force parallel to the surface. It opposes the relative motion (or attempted motion) of the two surfaces in contact.

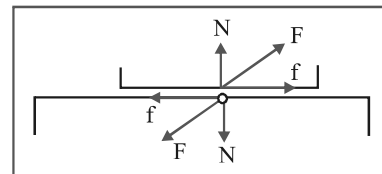

- (c) **Tension :** The force exerted by the end of a taut string, rope or chain is called the tension. The direction of tension is so as to pull the body while that of normal reaction is to push the body.
- (d) **Spring Force :** Every spring resists any attempt to change its length; the more you alter its length the harder it resists. The force exerted by a spring is given by  $F = -kx$ , where  $x$  is the change in length and  $k$  is the stiffness constant or spring constant (unit  $Nm^{-1}$ ).

**20. NEWTON'S LAWS OF MOTION**

**20.1 First law of motion**

- (a) Every body continues in its state of rest or of uniform motion in a straight line unless it is compelled by a resultant force to change that state.
- (b) This law is also known as **law of inertia**. Inertia is the property of inability of a body to change its position of rest or uniform motion in a straight line unless some external force acts on it.
- (c) Mass is a measure of inertia of a body.
- (d) A frame of reference in which Newton's first law is valid is called **inertial frame**, i.e., if a frame of reference is at rest or in uniform motion it is called **inertial**, otherwise **non-inertial**.

**20.2 Second law of motion**

- (a) This law gives the magnitude of force.
- (b) According to second law of motion, rate of change of momentum of a body is proportional to the resultant force acting on the body, i.e.,  $\vec{F} \propto \left( \frac{d\vec{p}}{dt} \right)$

Here, the change in momentum takes place in the direction of the applied resultant force. Momentum,  $\vec{p} = m \vec{v}$  is a measure of sum of the motion contained in the body.

- (c) **Unit force** : It is defined as the force which changes the momentum of a body by unity in unit time. According to

$$\text{this, } \vec{F} = \frac{d\vec{p}}{dt} = \frac{d}{dt} \left( m \vec{v} \right) = m \frac{d\vec{v}}{dt} + \vec{v} \frac{dm}{dt}.$$

If the mass of the system is finite and remains constant w.r.t. time, then  $(dm/dt) = 0$  and

$$\vec{F} = m \left( \frac{d\vec{v}}{dt} \right) = m \vec{a} = \left( \vec{p}_2 - \vec{p}_1 \right) / t$$

- (d) External force acting on a body may accelerate it either by changing the magnitude of velocity or direction of velocity or both.

- (i) **If the force is parallel or antiparallel to the motion**, it changes only the magnitude of  $\vec{v}$  but not the direction. So, the path followed by the body is a **straight line**.
- (ii) **If the force is acting  $\perp$  to the motion of body**, it changes only the direction but not the magnitude of  $\vec{v}$ . So, the path followed by the body is a **circle** (uniform circular motion).
- (iii) **If the force acts at an angle to the motion of a body**, it changes both the magnitude and direction of  $\vec{v}$ . In this case path followed by the body may be **elliptical, non-uniform circular, parabolic or hyperbolic**.

### 20.3 Third law of motion

- (a) According to this law, for every action there is an equal and opposite reaction. When two bodies A and B exert force on each other, the force by A on B (i.e., action represented by  $F_{AB}$ ), is always equal and opposite to the force by B on A (i.e., reaction represented  $F_{BA}$ ). Thus,  $F_{AB} = -F_{BA}$ .
- (b) The two forces involved in any interaction between two bodies are called **action and reaction**. But we cannot say that a particular force is action and the other one is reaction.
- (c) **Action and Reaction always act on different bodies.**

### 20.4 Applications of Newton's Laws of Motion

There are two kinds of problems in classical mechanics :

- (a) To find unknown forces acting on a body, given the body's acceleration, and

- (b) to predict the future motion of a body, given the body's initial position and velocity and the forces acting on it. For either kind of problem, we use Newton's second law ( $\Sigma F = ma$ ). The following general strategy is useful for solving such problems :

- (i) Draw a simple, neat diagram of the system.
- (ii) Isolate the object of interest whose motion is being analyzed. Draw a **free body diagram** for this object, that is, a diagram showing all external forces acting on the object. For systems containing more than one object, draw separate diagrams for each object. Do not include forces that the object exerts on its surroundings.
- (iii) Establish convenient coordinate axes for each body and find the **components of the forces along these axes**. Now, apply Newton's second law,  $\Sigma F = ma$ , in component form. Check your dimensions to make sure that all terms have units of force.
- (iv) **Solve the component equations** for the unknowns. Remember that you must have as many independent equations as you have unknowns in order to obtain a complete solution.
- (v) It is a good idea to check the predictions of your solutions for extreme values of the variables. You can often detect errors in your results by doing so.

## 21. SOME IMPORTANT POINTS CONCERNING NEWTON'S LAWS OF MOTION

- (a) The forces of interaction between bodies composing a system are called **internal forces**. The forces exerted on bodies of a given system by bodies situated outside are called **external forces**.
- (b) Whenever one force acts on a body it gives rise to another force called reaction i.e., a **single isolated force** is physically impossible. This is why **total internal force in an isolated system is always zero**.
- (c) According to Newton's second law,  $\vec{F} = \left( \frac{d\vec{p}}{dt} \right)$ . If  $\vec{F} = 0$ ,  $\left( \frac{d\vec{p}}{dt} \right) = 0$  or  $\left( \frac{d\vec{v}}{dt} \right) = 0$  or  $\vec{v} = \text{constant}$  or zero, i.e., a body remains at rest or moves with uniform velocity unless acted upon by an external force. This is Newton's 1st law.
- (d) The ratio of times for which the same force acts on two bodies of different masses initially at rest to have
- (i) equal displacement is :  $(t_1/t_2) = \sqrt{(m_1/m_2)}$ ;

## LAWS OF MOTION

(ii) equal final velocity is :  $(t_1/t_2) = (m_1/m_2)$ ;

(iii) equal final momentum is :  $(t_1/t_2) = 1/1$ .

Newton's second law can also be expressed as :  $Ft = p_2 - p_1$ . Hence, if a car and a truck are initially moving with the same momentum, then by the application of same breaking force, both will come to rest in the same time.

### 22. APPARENT WEIGHT OF A BODY IN A LIFT

(a) **When the lift is at rest or moving with uniform velocity, i.e.,  $a=0$  :**

$$mg - R = 0 \quad \text{or} \quad R = mg$$

$$\therefore W_{\text{app}} = W_0$$

(b) **When the lift moves upwards with an acceleration  $a$  :**

$$R - mg = ma \quad \text{or} \quad R = m(g + a) = mg \left( 1 + \frac{a}{g} \right)$$

$$\therefore W_{\text{app}} = W_0 \left( 1 + \frac{a}{g} \right)$$

(c) **When the lift moves downwards with an acceleration  $a$  :**

$$mg - R = ma \quad \text{or} \quad R = m(g - a) = mg \left( 1 - \frac{a}{g} \right)$$

$$\therefore W_{\text{app}} = W_0 \left( 1 - \frac{a}{g} \right)$$

Here, if  $a > g$ ,  $W_{\text{app}}$  will be negative. Negative apparent weight will mean that the body is pressed against the roof of the lift instead of floor.

(d) **When the lift falls freely, i.e.,  $a = g$  :**

$$R = m(g - g) = 0 \quad \therefore W_{\text{app}} = 0$$

( $W_{\text{app}} = R =$  reaction of supporting surface and  $W_0 = mg =$  true weight.)

### 23. PROBLEM OF MONKEY CLIMBING A ROPE

Let  $T$  be the tension in the rope.

(i) **When the monkey climbs up with uniform speed :**  $T = mg$ .

(ii) **When the monkey moves up with an acceleration  $a$  :**  $T - mg = ma$  or  $T = m(g + a)$ .

(iii) **When the monkey moves down with an acceleration  $a$  :**  $mg - T = ma$  or  $T = m(g - a)$ .

### 24. PROBLEM OF A MASS SUSPENDED FROM A VERTICAL STRING IN A MOVING CARRIAGE

Following cases are possible :

(a) **If the carriage (say lift) is at rest or moving uniformly**

(in translatory equilibrium), then  $T_0 = mg$ .

(b) **If the carriage is accelerated up with an acceleration  $a$ , then**

$$T = m(g + a) = mg \left( 1 + \frac{a}{g} \right) = T_0 \left( 1 + \frac{a}{g} \right)$$

(c) **If the carriage is accelerated down with an acceleration  $a$ , then**

$$T = m(g - a) = mg \left( 1 - \frac{a}{g} \right) = T_0 \left( 1 - \frac{a}{g} \right)$$

(d) **If the carriage begins to fall freely, then the tension in the string becomes zero.**

(e) **If the carriage is accelerated horizontally, then**

(i) mass  $m$  experiences a pseudo force  $ma$  opposite to acceleration;

(ii) the mass  $m$  is in equilibrium inside the carriage and

$$T \sin \theta = ma, \quad T \cos \theta = mg, \quad \text{i.e.,}$$

$$T = m\sqrt{g^2 + a^2};$$

(iii) the string does not remain vertical but inclines to the vertical at an angle  $\theta = \tan^{-1}(a/g)$  opposite to acceleration;

(iv) This arrangement is called accelerometer and can be used to determine the acceleration of a moving carriage from inside by noting the deviation of a plumbline suspended from it from the vertical.

### 25. CONSTRAINED METHOD

Let us try to visualize this situation

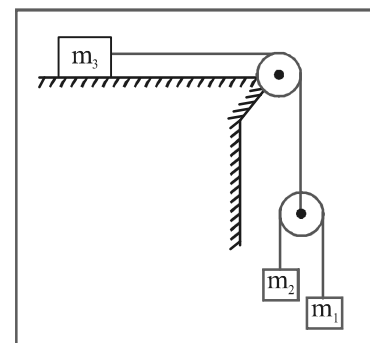

(i) If  $m_3$  was stationary, then magnitude of displacements of  $m_1$  and  $m_2$  would be same and in opposite direction.

Let us say  $x$  (displacement of  $m_1$  and  $m_2$  when  $m_3$  is stationary).

(ii) Now consider the case when  $m_3$  displaces by  $x_1$ , then

net displacement of

$$m_1 = x_1 - x$$

$$m_2 = x_1 + x$$

$$m_3 = x_1$$

(iii) Differentiate it twice we have

$$a_{m_3} = a_1$$

$$a_{m_1} = a_1 - a$$

$$a_{m_2} = a_1 + a$$

This problem can be approached in other way. Which is more mathematical and do not require much of visualisation.

**Steps involved to approach problems of multiple pulleys of system having different accelerations :**

- (i) Define a fixed point/axis.
- (ii) Locate positions of all movable points from fixed point/axis.
- (iii) (a) Write down the relation between length of the string and the position of different movable points.  
(b) No. of relation must be equal to no. of string.
- (iv) Differentiate it twice to get the relationship between acceleration of different objects.

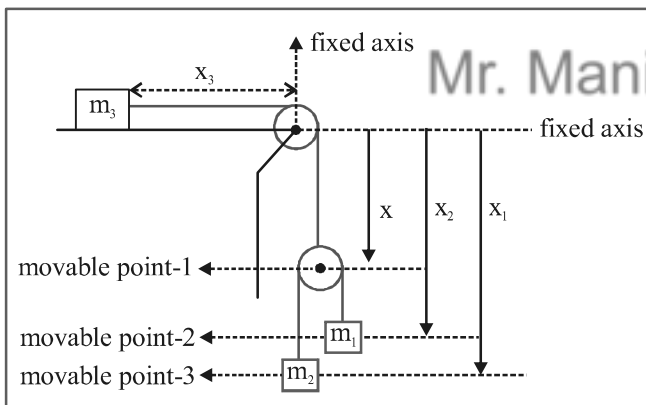

**For string connecting  $m_1$  and  $m_2$  :**

Let the length of the string be  $l_1$

$$l_1 = (x_2 - x) + (x + x) + \pi r$$

↓
↓  
 Constant                      Constant

On differentiating it twice :

$$0 = (a_2 - a) + (a_1 - a) + 0 \Rightarrow a = \frac{a_1 + a_2}{2}$$

**For string connective  $m_3$  and pulley :**

Let the string length be  $l_2$

$$l_2 = x + x_3$$

↓
↓
↓  
 Constant    length is    length is  
                   increasing    decreasing

**Note :** If Length is decreasing then differentiation of that length will be negative.

∴ On differentiating twice we have

$$0 = a + (-a_3)$$

$$a = a_3$$

Now, we can apply  $F = ma$  for different blocks.

Solve for  $a_3$ ,  $a_1$   $a_2$  and Tension.

**26. FORCE OF FRICTION**

Whenever two rough surfaces are in contact, sliding between the surfaces is opposed by the force of friction which the surfaces exert on each other. The force of friction acts parallel to the surfaces in contact and on both the surfaces.

**26.1 Static Friction**

If the tendency to slide against each other is too small to cause actual sliding motion, the force of friction is called as *the force of static friction*. The magnitude of this force balances the net applied force. Hence if there is no sliding between the surfaces. Force of static friction = net applied force parallel to the surfaces.

**26.2 Critical Point (Maximum Static friction)**

If the sliding between the surfaces is about to begin, the static friction is at its maximum value which is equal to  $\mu_s N$ , where  $N$  = normal reaction between the surfaces and  $\mu_s$  = coefficient of static friction. In this situation, we say that the surfaces are at their point of sliding and are exerting a force  $\mu_s N$  on each other so as to oppose sliding.

**26.3 Kinetic Friction**

If actual sliding is taking place between the surfaces, the force of friction is called as *force of kinetic friction* or the *force of sliding friction* ( $f_k$ ).

$$f_k = \mu_k N \text{ where } \mu_k = \text{coefficient of kinetic friction.}$$



Frictia always opposes relative motion between the surfaces in contact.

**LAWS OF MOTION**

**SOME IMPORTANT CASES**

Case	Diagram	Result
(a) When two bodies are kept in contact and force is applied on the body of mass $m_1$ .		(i) $a = \frac{F}{m_1 + m_2}$ , (ii) $N = \frac{m_1 F}{m_1 + m_2}$
(b) When two bodies are kept in contact and force is applied on the body of mass $m_2$ .		(i) $a = \frac{F}{m_1 + m_2}$ , (ii) $N' = \frac{m_2 F}{m_1 + m_2}$
(c) When two bodies are connected by a string and placed on a smooth		(i) $a = \frac{F}{m_1 + m_2}$ , (ii) $T = \frac{m_1 F}{m_1 + m_2}$
(d) When three bodies are connected through strings as shown in fig and placed on a smooth horizontal surface.		(i) $a = \frac{F}{(m_1 + m_2 + m_3)}$ (ii) $T_1 = \frac{m_1 F}{(m_1 + m_2 + m_3)}$ (iii) $T_2 = \frac{(m_1 + m_2) F}{(m_1 + m_2 + m_3)}$
(e) When two bodies of masses $m_1$ & $m_2$ are attached at the ends of a string passing over a pulley as shown in the figure		(i) $a = \frac{(m_1 - m_2) g}{(m_1 + m_2)}$ (ii) $T = \left( \frac{2m_1 m_2}{m_1 + m_2} \right) g$

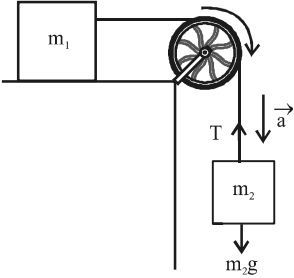
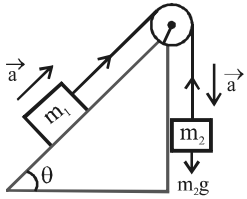
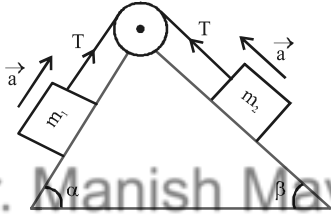
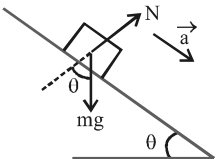
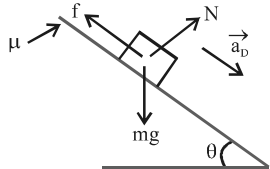
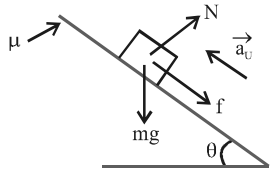
<p><b>(f)</b> When two bodies of masses <math>m_1</math> &amp; <math>m_2</math> are attached at the ends of a string passing over a pulley in such a way that mass <math>m_1</math> rests on a smooth horizontal table and mass <math>m_2</math> is hanging vertically.</p>		<p>(i) <math>a = \frac{m_2 g}{(m_1 + m_2)}</math>, (ii) <math>T = \frac{m_1 m_2 g}{(m_1 + m_2)}</math></p>
<p><b>(g)</b> If in the above case, mass <math>m_1</math> is placed on a smooth inclined plane making an angle <math>\theta</math> with horizontal as shown in figure, then.</p>		<p>(i) <math>a = \frac{(m_2 - m_1 \sin \theta) g}{m_1 + m_2}</math>                  (ii) <math>T = \frac{m_1 m_2 g (1 + \sin \theta)}{(m_1 + m_2)}</math>                  (iii) If the system remains in equilibrium, then <math>m_1 g \sin \theta = m_2 g</math></p>
<p><b>(h)</b> In case (f), masses <math>m_1</math> and <math>m_2</math> are placed on inclined planes making angles <math>\alpha</math> &amp; <math>\beta</math> with the horizontal respectively, then</p>		<p>(i) <math>a = \frac{g(m_1 \sin \alpha - m_2 \sin \beta)}{(m_1 + m_2)}</math>                  (ii) <math>T = \frac{m_1 m_2}{(m_1 + m_2)} (\sin \alpha + \sin \beta) g</math></p>
<p><b>(i)</b> When a body is moving on smooth inclined plane.</p>		<p><math>a = g \sin \theta</math>, <math>N = mg \cos \theta</math></p>
<p><b>(j)</b> When a body is moving down on a rough inclined plane.</p>		<p><math>g (\sin \theta - \mu \cos \theta)</math></p>
<p><b>(k)</b> When a body is moving up on a rough inclined plane.</p>		<p><math>a_u = g (\sin \theta + \mu \cos \theta)</math></p>